



3 phase,60HZ@1800RPM

Prime power	KVA	313
	KW	250
Standby power	KVA	344
	KW	275
Voltage	V	440/254
Ampere	A	450.8



Notes:

- 1) Ambient condition: 1,000 m,25°C
- 2) Available in following voltages:220/127,208/120,416/240,440/254,460/266,480/277
- 3) Prime Power (PRP): Prime power is available for an unlimited number of annual hours in variable load application, in accordance with GB/T2820-97 (eqv ISO8528) ; A 10% overload capability is available for a period of 1 hour within a 12-hour period of operation.
Standby Power Rating (ESP): The standby power rating is applicable for supplying emergency power for the duration of a utility power interruption. No overload, utility parallel or negotiated outage operation capability is available at this rating.

Features

- Engine (DOOSAN P126TI)
- Radiator 40°C max, fans are driven by belt, with safety guard
- Alternator: single bearing Mecc Alte alternator IP23, insulation class H/H)
- Main line circuit breaker
- Standard automatic control panel
- Batteries, rack and cable
- 24V charge alternator
- Absorber
- Dry type air filter, fuel filter, oil filter
- Ripple flex exhaust pipe, exhaust siphon, flange, muffler
- User manual

Performance Specification,Warranty and Criterion

Performance Specification		Telephone Influence Factor	
Voltage Regulation	≥±5%	TIF	<50
Voltage Regulation, Stead State	≤±1%	THF	<2%
Sudden Voltage Warp (100% Sudden Reduce)	≤+25%	Warranty	
Sudden Voltage Warp (Sudden Increase)	≤-20%	:DQWLVDFFRGLWRRMWDQDGFRLWLRQD PRWK2BHDDIWHUQWDOODWLRQD DFFRQDWHGVEMHFWRWVKHDLHBB6HMFHDQSDWV DHDØLODEOHIBP(1&GLVWUEWRVLRQ ORFDWLRQ	
Voltage Stable Time (100% Sudden Reduce)	≤6S	Criterion	
Voltage Stable Time (Sudden Increase)	≤6S	● Genset design comply to ISO8528/GB2820-97	
Frequency Reduce	0-5% adjustable	● Alternator design Compliance with GB755, BS5000, VDE0530, NEMAMG1-22, IED34-1, CSA22.2 and AS1359 standards	
Frequency Regulation, Stead State	5%		
Frequency Waving	≤0.5%		
Sudden Frequency Warp (100% Sudden Reduce)	≤+12%		
Sudden Frequency Warp (Sudden Increase)	≤-10%		
Frequency Recovery Time (100% Sudden Reduce)	≤5S		
Frequency Recovery Time (Sudden Increase)	≤5S		

Engine specification		Alternator specification		
Brand	DOOSAN	Brand	Mecc Alte	
Model	P126TI	Model	ECO38 1L4A	
Air Intake System	Turbo charged & intercooled	Number of Phase	3	
Fuel System	Zexel P type fuel pump	Connecting Type	"Y" type connecting	
Cylinder Arrangement	6 in line	Number of Bearing	1	
Displacement	11.051L	Power Factor	0.8	
BorexStroke	123x155 mm	Protection Grade	IP23	
Compression Ratio	17.1:1	Altitude	≤1000m	
Governor Type	Electronic Governor	Exciter Type	Brushless, self-exciting	
Frequency Regulation, Steady State:	≤1.5%	Insulation Class, Temperature Rise	H/H	
Starting system	E	Alternator Capacity	360KVA	
Battery voltage	12VDC	Telephone Influence Factor (TIF)	<50	
Fuel consumption(L/h)	100% load	70.3	THF	<2%
	75% load	52.3	Voltage Regulation, Steady State	≤±1%
	50% load	36.2	Alternator Efficiencies	93.0%
	25% load	20.3	Air Cooling Flow	0.8m3/s

Exhaust System		Air Intake System	
Exhaust Gas Flow	67.3m3/min	Max Intake Restriction	6.23kPa
Exhaust Temperature	540°C	Cooling Fan Air Flow	433m3/min
Max Back Pressure	5.9kPa	Intake Air Flow	27.68m3/min

Oil System		Cooling System	
Max Oil Capacity	23L	Total Coolant Capacity	51L
Oil Consumption	TBD	Thermostat	71-85°C
Max oil temperature	120°C	Max Water Temperature	103°C
Oil Pressure at Rated RPM	≥250kpa		



Control system

Deepsea brand DSE7320 (Standard)

Features:

- Auto Mains (Utility) Failure control module
- Remote PC and via SMS textalerts (with external modem)
- LED and LCD alarm indication
- Include USB, RS232 and RS485 ports
- Support for up to three remote display units
- Generator measurements (50/60 Hz): U1-U3, I1-I3, Hz, kW, kVAr, kWh
- Charge alternator failure alarm
- 3 phase Generator protections:
 - Over-/under voltage
 - Over-/under frequency
 - Current/voltage asymmetry
 - Overcurrent/overload
- Analog oil pressure, water temperature, fuel level, battery voltage, engine speed
- Load switching (load shedding and dummy load outputs)
- CAN and Magnetic Pick-up/Alt.sensing
- Automatic load transfer





Optional parts

Engine	Fuel System	Control System
● Heater	● Daily Fuel Tank	● Remote Control Panel
● Battery Charger	● Water Separator	● Auto Transfer Switch
	● Fuel Level Sensor	● Paralleling System
Alternator	Others	Data
● Anti Condensation Heater	● Soundproof Type	● Engine Parts Drawing List
● Drop CT (For Paralleling)	● Trailer Type	● Spare parts
● PMG	● Containerized Type	

Dimension and Weight

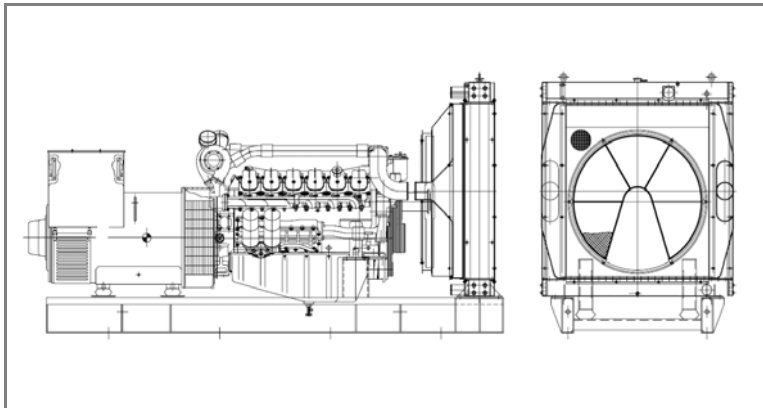

Open Type Genset
Dimension: 3100x1400x2000 mm
Weight: 2600 kg

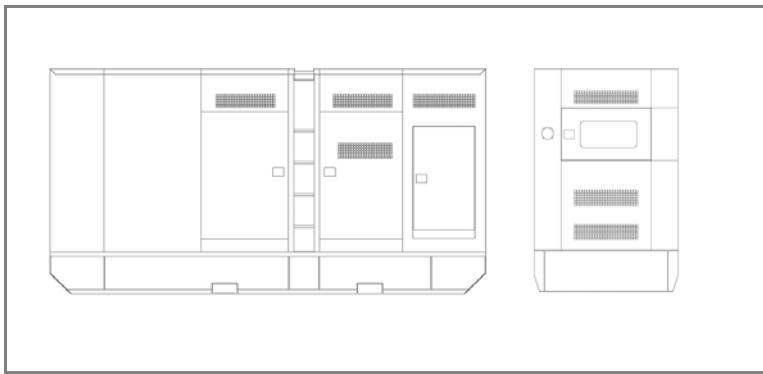

Soundproof Type Genset
Dimension: 4000x1500x2250 mm
Weight: 3500 kg

ENERGY360

Kra42 #54A 71 INT101 ITAGUI. PBX: (4)5600530

E-mail: info@energy360.com.co

